



TDRFORCE BW1000A Bottled Water Dispenser Pump Instruction Manual

[Home](#) » [TDRFORCE](#) » TDRFORCE BW1000A Bottled Water Dispenser Pump Instruction Manual 

Contents

- 1 TDRFORCE BW1000A Bottled Water Dispenser Pump
- 2 Product Information
- 3 Product Usage Instructions
- 4 TOOLS REQUIRED TO INSTALL SYSTEM
- 5 MAINTENANCE AND SANITATION Equipment
Required
- 6 Troubleshooting
- 7 Warranty Card
- 8 Documents / Resources

TDRFORCE®

TDRFORCE BW1000A Bottled Water Dispenser Pump



Product Information

- **Models:** BW1000A, BW1020A, BW2000, BW4003A, BW4020A, BW6000A
- Water supply for ice-maker, refrigerator, and coffee machine
- Applicable to 5-gallon water jugs
- **Input:** AMPS
- **Power:** Annual power consumption
- **Flow:** Maximum flow rate
- **Max head:** Maximum head height
- **Max pressure:** Maximum pressure
- **Plug:** Type of plug
- **Cord:** Length of power cord
- **Inlet tube:** Single or double inlet tubes
- **Outlet hose:** Type of outlet hose
- **Material:** Material used in construction
- **Weight:** Weight of the pump

Product Usage Instructions

1. Check if the pump has been damaged during transport. If damaged, contact TDRFORCE online services.
2. Ensure that the main voltage corresponds to the voltage specified in the instruction manual.
3. Ground the motor before any other operation.
4. Refer to the installation instructions provided in the manual.
5. Follow the cautions mentioned in the manual, such as checking power, filling water manually if needed, checking buoy movement, refilling the bottle, securing connections, fixing leaks, and checking pressure and float switches.
6. If troubleshooting is required, refer to the troubleshooting section in the manual for specific defects and their

solutions.

7. Keep the warranty card properly for customer contact and warranty information.

Models



Specifics

Input	110V AC
AMPS	0.25 AMP
Power	36W
Annual Power consumption	106 kW·h
Flow	2 GPM
Max head	13 ft
Max pressure	50 psi
Plug	3-way standard US plug
Cord	4.4 ft
Inlet tube	1.8 ft
Outlet hose	20 ft
Material	PE
Weight	5.1 lb

- A. Pump Module with On/Off Rocker Switch, 3.5 ft. (1m) Cord
- B. Suction Wand and Hose Assembly
- C. 20 ft (6.1m) of 1/4 in. (6.35mm) Discharge Tube
- D. **Kit Fitting**: Hose port/connector, compression nut and sleeve.
- E. Universal wall transformer.

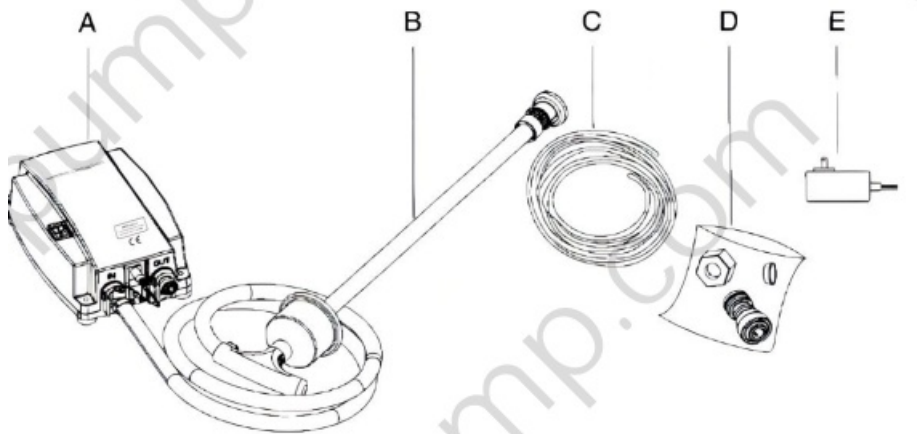

TOOLS REQUIRED TO INSTALL SYSTEM

1. Medium sized Wrench
2. 7/16 in. (11.12mm) or 1/2 in (12.7mm) Drill Bit
3. Power Drill
4. Sharp Knife or Box Knife



1

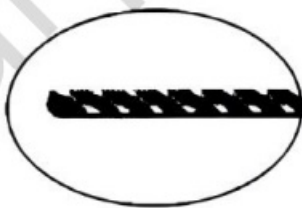

2

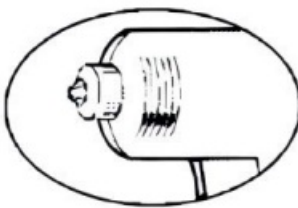

3

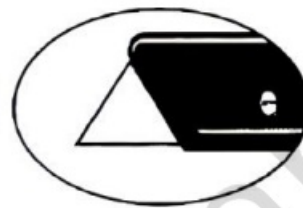

4

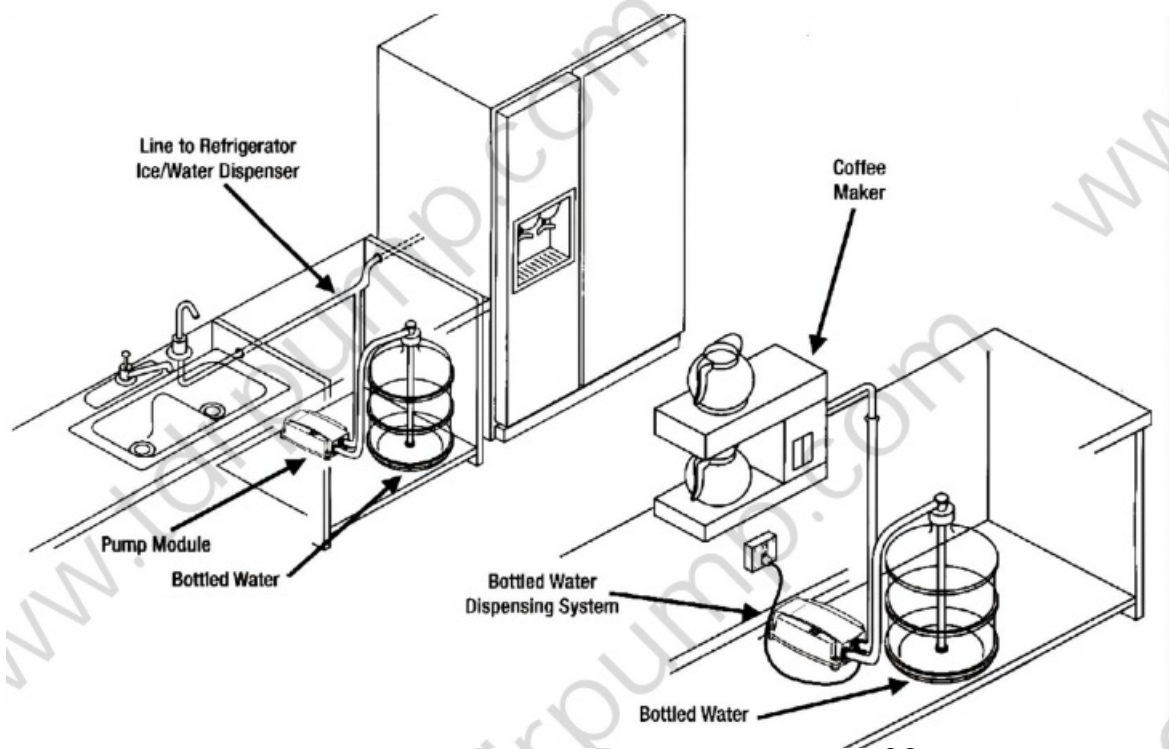

PLUMBING

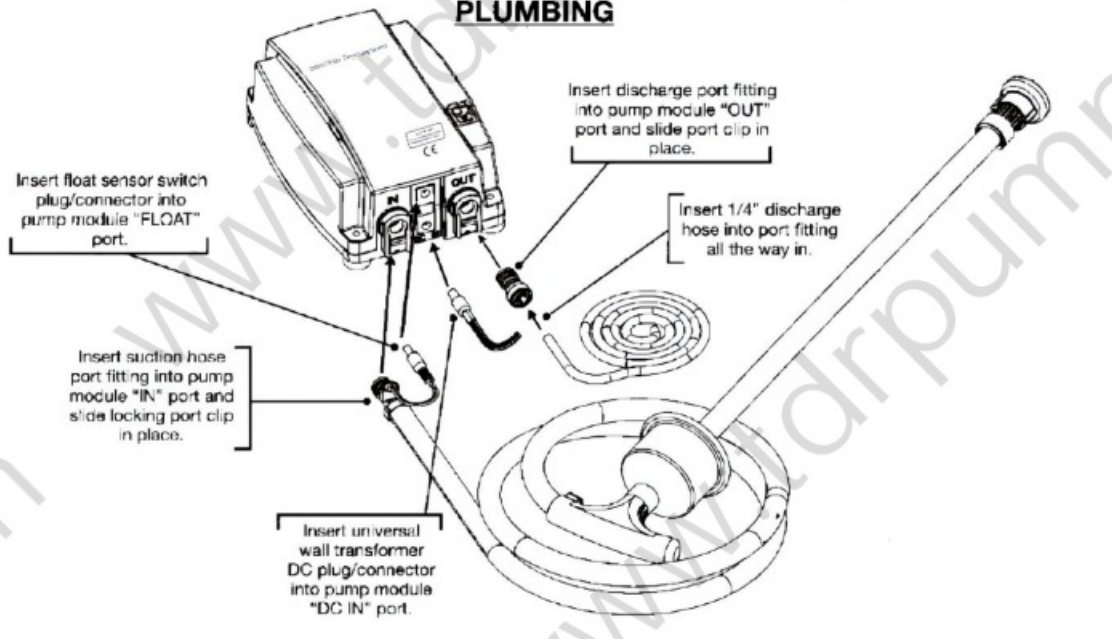

PLUMBING

There is 20 feet of 1/4" O.D. polyethylene tubing supplied with the Bottled Water Dispensing System. Carefully measure the distance between the pump module outlet and the appliance water inlet or optional faucet, and cut the tubing clean and square to prevent fitting leaks. If the refrigerator and optional faucet are being connected, use the 1/4" tube T[^] fitting and place it in an accessible location. Remove the plug from the pump module outlet port by pushing the collet against the body while sliding the plug out of the fitting. See removal of plugs (Page 4) Push the cleanly cut tubing end into the pump module outlet port, past the o-ring to tube stop. Route tubing to the refrigerator water valve and connect it to the water inlet valve in the back of the refrigerator by using the tube connector fitting. First slip nut over the tube, then place the ferrule over the tube, then install onto the refrigerator water valve fitting and tighten. For installation and use with commercial coffee and tea brewing equipment: Many commercial coffee and tea brewing machines can be connected to a water supply line. Ensure that you have a 1/4" I.D. connection fitting at the water inlet that can accept the supplied 1/4" O.D. tubing.

These brewing machines have a factory installed device that restricts incoming water to a safe pressure that won't damage the brewing machine. This device is usually referred to as an inlet pressure regulator or flow restrictor, and limits incoming water pressure to approx. 90-100psi. If you intend to use the system with one of these brewing machines, you should remove the brewing machine's inlet restrictor device. Consult the brewing machine manufacturer for details. Failure to remove the brewing machine's restrictor may cause the series pump to cycle

itself off and on repeatedly, leading to premature motor failure of the unit. This type of failure is not covered under warranty. Use of filter devices with your commercial brewer is unnecessary; see below. For installation on refrigerators with ice making and/or water dispensing functions. Do not use any external filtration devices. These will cause the pump to over-cycle, possibly causing premature pump failure, not covered under warranty. If your refrigerator has factory installed internal filtration that must remain in place as part of the water line, this too may cause over-cycling resulting in pump failure. Contact the refrigerator maker and inquire about obtaining an empty or dummy filter housing for use instead of the standard filter model. If none is available, the use of a small accumulator tank will be necessary.

SUCTION WAND INSTALLATION

To install the suction wand into standard 5 gallon bottle, place bottle close to system and remove bottle cap, then install suction wand into bottle.

(Note: If bottle is over filled), dispense enough water to allow the suction wand to be installed to the bottom of the bottle). Push suction wand bottle cap over bottle and push wand to bottom center of bottle.

SUCTION WAND REMOVAL AND CHANGING BOTTLES

Before removing suction wand from empty bottle, move bottle to an open area outside of cabinet. Put new bottle next to empty bottle, clean neck and cap area with detergent, and remove cap. Remove suction wand from empty bottle by lifting wand cap with a rocking motion and pull cap off bottle, sliding suction wand out of the bottle and place directly into new bottle while sliding cap over new bottle neck. Do not attempt to remove suction wand by pulling on the soft plastic tube, which can result in permanent breakage of suction wand.

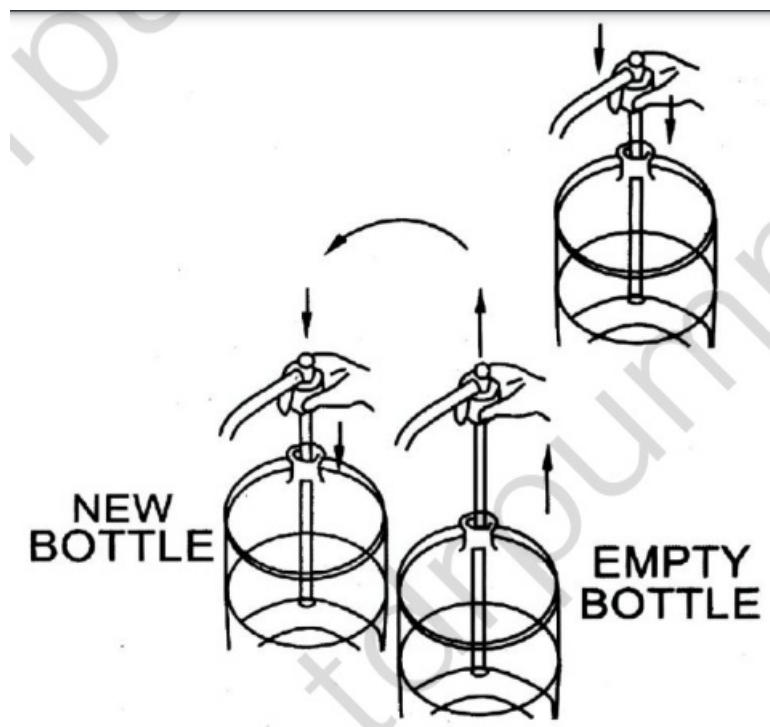

Do not place suction wand on floor, counter, or sink as this could contaminate the suction wand assembly. If bottle is over filled, dispense enough water to allow the suction wand to be pushed to bottom of bottle.

Cautions

1. After unpacking the pump, please check if it has been damaged during transport. If so, please contact TDRFORCE online services at the first time.
2. Make sure that the main voltage corresponds to the voltage specified on the instruction manual.
3. The motor must be absolutely grounded before any other operation.
4. Do not submit the pump body to mechanical stress.

5. The pump must be sheltered from weather (sun- rain- wind- snow- chill).
6. Place the pump as near as possible to the water bottle and appliance.
7. The pump could be only used in fresh water circulating.
8. Do not use any external filtration devices, which may cause the pump to over-cycle.
9. Do not place this product into a dishwasher as it will cause electrical failure of the pump. Maintenance and sanitation should be in accord with the instruction.

TEMPERATURE WARNING

For additional protection, thermal cut-off device which is activated at 158°F / 70°C. Under normal operation, it will take 45-50 minutes for the motor to reach 158°F/ 70°C at open flow condition. Once the power is cut off to the unit, it takes 15-20 minutes to reset. Power is restored after motor temperature has dropped to 131°F / 55°C

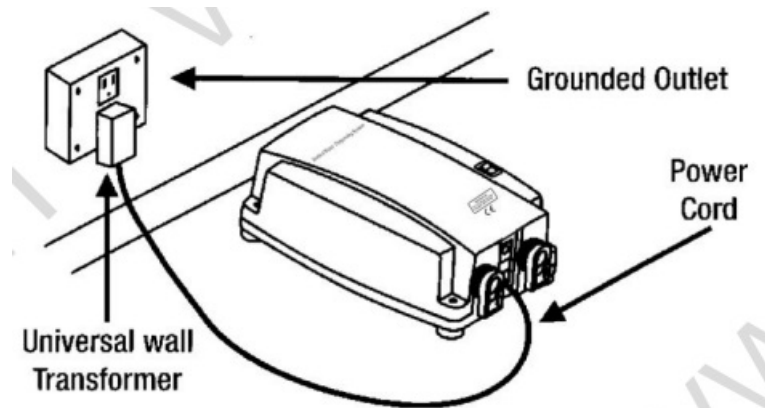

WARNING! Damaged power cord must be replaced by factory authorized service only!

How the System Works

The Bottled Water Dispensing System was designed to pump water from a commercially available 5-gallon water bottle. The system will deliver the water under pressure to an individual drinking water faucet, the water inlet of a refrigerator to the icemaker and chilled drinking water tap, and to certain commercial coffee / tea brewers. When the suction wand is inserted into the 5-gallon bottle, it will activate the float switch on the end of the wand and turn on the pump. This same float switch shuts off the system when the bottle is empty. The wand has a built in back-flow preventor valve that prevents water in the system from flowing back into the bottle, or spilling while changing bottles. The heart of the system is the pump module that automatically adjusts the flow and pressure to fill an appliance or faucet, and stops automatically.

SYSTEM START-UP

Before the Bottled Water Dispensing System is put into service, the system should be sanitized by following the maintenance and sanitation clean in-place procedure. After the Bottled Water Dispensing System has been mounted in a suitable location with the suction wand installed into the bottle and the discharge tube routed to the appliance water inlet (or to the optional drinking water faucet), the 115 volt AC and 230 volt AC systems must be plugged into a grounded outlet, Turn the dispensing system on by placing the on/off switch in the on position and operating the appliance dispensing valve or the drinking water faucet to vent all the air from the Bottled Water Dispensing System. After air is evacuated from the system, close the appliance dispensing valve or the water faucet and the pump will stop automatically until you open the water dispenser valve or water faucet. Follow manufacturer's plumbing and operating instructions with commercial coffee and tea brewers. For refrigerators with icemaker only, the seal at the icemaker connection should be loosened or disconnected to vent the trapped air in the system. When water is present at the connection, reconnect, tighten and check for leaks. Once the system is vented, it will not require venting again even after bottle changes.

MAINTENANCE AND SANITATION Equipment Required

- Two (2) 2 1/2 Gallon Household Pails

- One (1) Roll of Paper Towels
- One (1) Small Container of Household Bleach



CAUTION! 135°F(57.2°C) Maximum Water Temperature

Clean In-Place Procedure Using the on/off switch on the front of the enclosure, turn Bottled Water Dispensing System off by putting the switch in the off position Fill a clean pail (A) with two (2) gallons of hot tap water (135°F/57.2°C), adding one (1) ounce of household bleach. Remove the suction wand from the pure water bottle and submerge the bottle cap end into pail (A), taking care to ensure that the metal hose clamp connecting the hose to the suction wand is totally immersed in the water/bleach solution, for ten minutes and then wash underside of cap and suction tube exterior with a clean paper towel. If using the optional faucet, disconnect the tubing. Remove the faucet, immersing it in the water/bleach solution for ten minutes. Wash the faucet exterior with clean paper towel; install the faucet and reconnect the tubing. Place suction wand into clean empty pail (B) and dispose of solution in pail (A).



Refill the cleaned pail (A) with two (2) gallons of hot tap water(135°F/57.2°C) adding one (1) ounce of household bleach and place suction wand into pail with bottle cap up.

Disconnect the discharge tube from the faucet or the refrigerator and place into the empty second pail (B). (Do not use pail with clean water and chlorine solution): Turn dispensing system on, by placing on/off switch in the on position and dispense all of the chlorine solution into pail (B). Place discharge tube into pail (A) and dispose of bleach, and rinse pail (B). Replace tube into pail (B).



Refill pail (A) with two (2) gallons of hot tap water (135°F/57.2°C), adding one (1 ounce of household bleach. Dispense bleach as in step #6. Reinstall suction wand into new bottle of pure water and reconnect discharge tube into refrigerator or faucet and dispense 12 to 18 ounces of water, or until bleach taste is removed. Cleaning should be performed at least four (4) times per year. CAUTION Do not place Bottled Water Dispensing System into a dishwasher as it will cause electrical failure of pump and controls.



Troubleshooting

TYPE OF DEFECT	CAUSE	SOLUTION
-The dispenser doesn't pump water	<ul style="list-style-type: none"> • Power failure. • Long time unused. Air in the pipes. • Buoy of the inlet pipe stuck. • Empty bottle. 	<ul style="list-style-type: none"> • Check the power. • Keep the power on and fill some water manually from the inlet pipe. Try several times until it starts pumping. • Check the buoy to make sure it can move freely. • Refill the bottle
<ul style="list-style-type: none"> • Outlet leaks 	<ul style="list-style-type: none"> • Installation error. • Loose connection between the dispenser and the machine • Cracked tubes 	<ul style="list-style-type: none"> • Push tube all the way into tube's top. <p>Remove tube and cut 1/4" off end, square and reinstall.</p> <p>Check correct tube size in fitting. Tube size is 1/4"</p> <p>O.D. Fitting should be 1/4" I.D.</p> <ul style="list-style-type: none"> • fasten the connection between the tube and the machine. • Replace the cracked tubes.
<ul style="list-style-type: none"> • The pump doesn't shut-off 	<ul style="list-style-type: none"> • Leaks at tubes, tube fittings and other connections • Pressure switch failure • Float switch stuck 	<ul style="list-style-type: none"> • Fix the leaks. • Check pressure switch by turning faucet off and on. • Check float switch position in bottle and make sure it can move freely.
<ul style="list-style-type: none"> • The dispenser continuously turns off and on in using 	<ul style="list-style-type: none"> • Installation failure 	<ul style="list-style-type: none"> • Check for restriction device at appliance inlet. Check for filter unit in line.

Warranty Card

Customer contact, please keep it properly.

Dear customer

Thank you for choosing products of TDRFORCE. In order to provide you with more satisfactory service and better protect your rights, please read this regulation carefully and keep the warranty card properly.

Regulations

1. For any quality issue of TDRFORCE product within 180 days after sale, we offer no-hassel return service for our customers;
2. Please contact our Amazon online customer service or sales04@tdrshine.com before return;
3. Valid evidence of purchase will be essential such as order ID or warranty card;
4. Valid evidence showing product problems shall be provided in the contact such as videos, photos or detailed descriptions.
5. Warranty card shall be filled out and attached with the return product.

Please notice

The following situations are not applicable to our nohassel return policy.

1. Product damage caused by installation or use not in accordance with the instruction manual;
2. Product beyond 180 days after sale;
3. Product return with no reason;
4. Product damage caused by self-disassembly or sabotage;
5. Product damage caused by force majeure such as earthquakes, fires, etc.

- **Buyer's Name:** Tele _____
- **E-mail:** _____
- **Order ID:** Return Address _____
- **Product Problem Description** _____

Documents / Resources

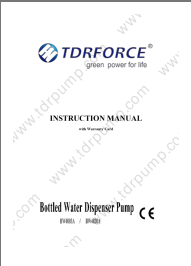
 <p>The image shows a document cover for the TDRFORCE BW1000A Bottled Water Dispenser Pump. It features the TDRFORCE logo with the tagline 'green power for life'. Below the logo, it says 'INSTRUCTION MANUAL' and 'Bottled Water Dispenser Pump'. There is also a CE mark and some small text at the bottom.</p>	<p>TDRFORCE BW1000A Bottled Water Dispenser Pump [pdf] Instruction Manual BW1000A Bottled Water Dispenser Pump, BW1000A, Bottled Water Dispenser Pump, Water Dispenser Pump, Dispenser Pump, Pump</p>
---	---