

Item: _____ Model #: _____
Quantity (Qty): _____ Project: _____

Gas Hot Plate

PHP12G-CT | PHP24G-CT | PHP36G-CT | PHP48G-CT | PHP60G-CT



PHP24G-CT

The **Gas Hot Plate** was developed to provide the best cooking experience, combining high standard quality, performance and durability to satisfy all professional kitchens demands.

STANDARD FEATURES

- Available in 12" (305 mm), 24" (610 mm), 36" (915 mm), 48" (1,220 mm) and 60" (1,525 mm) width.
- Stainless steel panel and sides.
- 12" x 12" cast iron top grates designed for easy movement of pots across top sections.
- Deflectors to direct waste to crumb/drip pan.
- Large front panel, promoting safety and great functionality.
- Black paint injected aluminum knobs providing for better toughness and durability.
- 1-year parts and labor warranty.
- 4" adjustable chromed carbon steel legs.
- Easily removable stainless steel crumb/drip pan.
- Crumb/drip pan capacity:

	Model				
	PHP12G - CT	PHP24G - CT	PHP36G - CT	PHP48G - CT	PHP60G - CT
Collecting tray capacity	0.61 gal (2.3 L)	2.20 gal (8.4 L)	3.81 gal (14.4 L)	6.07 gal (23 L)	7.62 gal (28.8 L)

Note: The PHP60G - CT model has two crumb/drip pan with capacity of 3.81 gal (14.4L) in its structure.

CERTIFICATION:



Certified to
ANSI/NSF4

AREA FOR CONSULTANT / CONTRACTOR:

OPTIONS & ACCESSORIES

- Product installation kit (pressure regulating valve).
- Propane Gas (LP) Conversion Kit.
- Pilot lighter.

Gas Hot Plate

PHP12G-CT | PHP24G-CT | PHP36G-CT | PHP48G-CT | PHP60G-CT

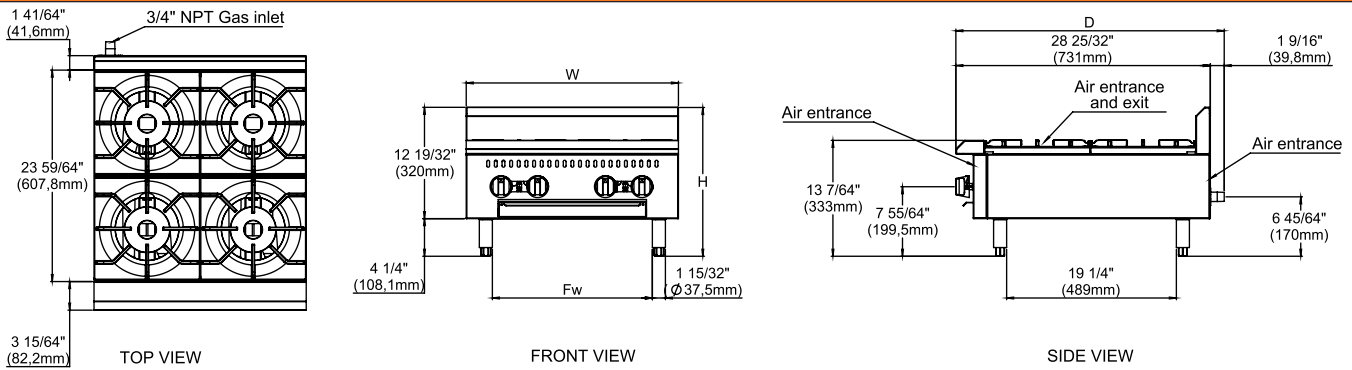

Model	Exterior Product Dimensions & Weight					Shipping Crate Dimensions & Weight			
	Width (W)	Depth (D)	Height (H)	Fw	Weight	Width	Depth	Height	Weight
PHP12G - CT	12" (305 mm)	30 33/64" (775 mm)	16 27/32" (428 mm)	9 5/64" (230.5 mm)	70 lb (32 kg)	16 17/32" (420 mm)	34 1/4" (870 mm)	19 19/64" (490 mm)	93 lb (42 kg)
PHP24G - CT	24" (610 mm)	30 33/64" (775 mm)	16 27/32" (428 mm)	18 3/32" (459.5 mm)	123 lb (56 kg)	27 61/64" (710 mm)	34 1/4" (870 mm)	19 19/64" (490 mm)	154 lb (70 kg)
PHP36G - CT	36" (915 mm)	30 33/64" (775 mm)	16 27/32" (428 mm)	31 9/32" (794.5 mm)	176 lb (80 kg)	40 5/32" (1020 mm)	34 1/4" (870 mm)	19 19/64" (490 mm)	218 lb (99 kg)
PHP48G - CT	48" (1220 mm)	30 33/64" (775 mm)	16 27/32" (428 mm)	43 9/32" (1099.5 mm)	238 lb (108 kg)	52 31/32" (1320 mm)	34 1/4" (870 mm)	19 19/64" (490 mm)	298 lb (135 kg)
PHP60G - CT	60" (1525 mm)	30 33/64" (775 mm)	16 27/32" (428 mm)	55 19/64" (1404.5 mm)	300 lb (136 kg)	64 1/16" (1630 mm)	34 1/4" (870 mm)	19 19/64" (490 mm)	352 lb (160 kg)

UTILITY INFORMATION

GAS SUPPLY							
MODEL	BURNERS	PROPANE		NATURAL		MANIFOLD PRESSURE	
		kcal/h	BTU/h	kcal/h	BTU/h	Natural Gas	Propane Gas
PHP12G - CT	2	12,600	50,000	12,600	50,000	4" W.C	10" W.C
PHP24G - CT	4	25,200	100,000	25,200	100,000		
PHP36G - CT	6	37,800	150,000	37,800	150,000		
PHP48G - CT	8	50,400	200,000	50,400	200,000		
PHP60G - CT	10	63,000	250,000	63,000	250,000		

SPECIFICATIONS

- 25,000 BTU/h burners placed every, providing best performance.
- Manifold pressure is 4"W.C (Natural Gas) or 10" W.C (Propane Gas).
- 3/4 "NPT rear gas connect ang pressure regulator for both natural gas and propane.
- Check the altitude specifications above 2,000ft.

***NOTE:** In line with its policy to continually improve its product, Venancio USA reserves the right to change materials and specifications without notice.

- Specify the type of gas when ordering.
- Specify altitude when above 2,000 feet.

INSTALLATION INSTRUCTIONS

A pressure regulator sized for this unit is included. The gas line connecting to the range must be 3/4" or larger. If flexible connectors are used, the inside diameter must be 3/4" or larger. An adequate ventilation system is required for commercial cooking equipment. Information may be obtained by writing to the National Fire Protection Association, 1 Batterymarch Park, Quincy, MA 02269, www.NFPA.org. When writing, refer to NFPA No. 96.4. These units are manufactured for installation in accordance with ANSZ223.1A (latest edition), National Fuel Gas Code. Copies may be obtained from The American Gas Association, 400 N Capitol St. NW, Washington, DC 20001, www.AGA.org.

Gas Hot Plate